

GM-WSL Waterproof Slam Latch

Features

- Designed for waterproof compartment
- Suitable for marine applications such as exterior deck lockers
- Comes with a 3 mm spacing ring
- 6 mm and 9 mm spacer rings are available upon request

Material

- Stainless steel 316 or nylon

Notes

- Max. door thickness is 22 mm (with use of longer screws)
- Screw size #8

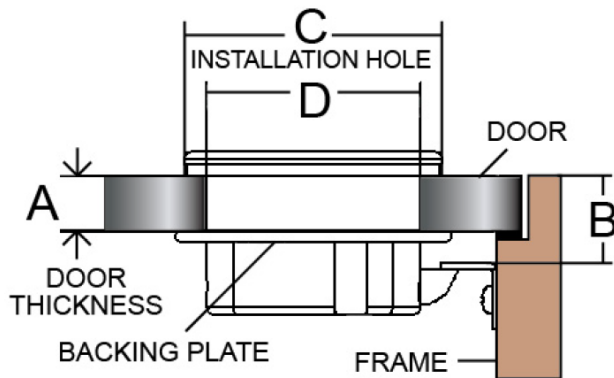

Part No.	Type	Housing	A	B	C	D
GM-WSL-J221520	Non Locking	Stainless Steel 316	10 ~ 13	25	61	51
GM-WSL-J221521	Locking					
GM-WSL-J221524	Non Locking	Nylon				
GM-WSL-J221525	Locking					